

RØDECASTER DUO

INTEGRATED AUDIO PRODUCTION STUDIO

The RØDECaster Duo is a compact and incredibly powerful all-in-one audio production solution for podcasters and content creators. It features two combo inputs with ultra-low-noise, high-gain Revolution Preamps™ for connecting both microphones and instruments, plus an integrated Series IV 2.4GHz wireless receiver for connecting RØDE wireless microphones, and a 3.5mm TRRS input for connecting a headset. Studio-grade APHEX® processing delivers superior audio quality, with perfectly tailored presets and flexible on-board editing making it easy to capture professional sounding recordings. Advanced Bluetooth® connectivity, dual USB-C interfaces, and Wi-Fi and Ethernet connections offer unrivalled integration with computers, smartphones, and other devices, and the fully customisable mixer allows the RØDECaster Duo to be configured to suit any application or setup. Six programmable SMART pads can be used to trigger everything from sounds and voice effects to mixer actions and MIDI for unmatched creative flexibility and control. The RØDECaster Duo is also incredibly simple to use, with a large high-resolution touchscreen and rotary encoder for easy navigation, intuitive controls, and professionally tailored presets.

- Fully integrated audio production studio for podcasters and content creators
- Ultra-low-noise, high-gain Revolution Preamps™ (-131.5dBV EIN, 76dB gain)
- Two high-quality Neutrik® combo inputs for connecting microphones, instruments and line-level devices
- Seven individually assignable channels with four broadcast-quality physical faders and three virtual faders
- High-performance quad-core audio engine
- Studio-grade APHEX® audio processing and on-board effects
- Six fully programmable SMART pads with bank switching
- Dual USB-C interfaces for connecting two computers or mobile devices
- Advanced Bluetooth® connectivity for high-quality phone call integration
- Multitrack or stereo recording to a microSD™ card, USB storage device or computer
- Two high-power headphone outputs, one TRRS headset output and two balanced ¼-inch line outputs
- 5.5-inch high-definition touchscreen with haptic feedback and rotary encoder for easy navigation and control
- Designed and made in RØDE's precision facilities in Sydney, Australia
- Seamless multi-location connectivity between RØDECaster Pro II and RØDECaster Duo devices, or via web-browser, with our integrated RØDE CallMe feature.

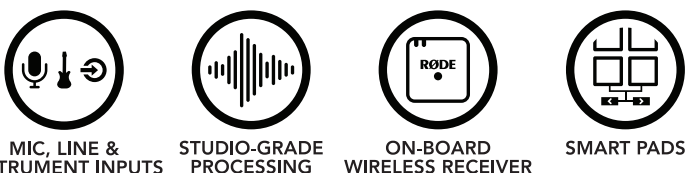

ACOUSTIC & ELECTRICAL SPECIFICATIONS

Frequency Range:	Mic Inputs: 20Hz - 20kHz Monitor Outputs: 20Hz - 20kHz
Microphone Input Impedance:	4KΩ
Instrument Input Impedance:	1MΩ
Preamplifier Gain Range:	0 - 76dB
Equivalent Noise:	-131.5dBV (A-weighted)
Line Output Maximum Level:	4dBu
Headphone Output Power:	250mW
Power Requirements:	USB-C PD (9V, 3A)
Analogue Audio Input Connectivity:	2 x combo jack (mic, instrument, line) 1 x 3.5 TRRS headset jack (I/O)
USB Interface 1:	1 x 2-in/14-out multichannel device, 1 x 2-in/2-out with mix-minus
USB Interface 2:	1 x 2-in/2-out with mix-minus
Bit Depth:	24-bit
Sample Rate:	48kHz
Recording Storage:	microSDHC, microSDXC, USB-C removable drive (exFAT – minimum 100MB/s)

RØDE

ACOUSTIC, VIDEO & ELECTRICAL SPECIFICATIONS

Data Transfer:	USB 3.0 SD card reader 130MB/s
Network Connectivity:	WiFi 802.11g/n/ac 2.4GHz and 5GHz, Ethernet 100/100 (WPA2 or WPA2-Personal network types)
Internal Storage (GB):	4GB (SMART pads)
OS Requirements:	macOS 10.15 or later, Windows 10 Version 1803 or later, Windows 11

MECHANICAL SPECIFICATIONS

Weight (grams):	1131
Dimensions (millimetres):	Length: 235 Width: 225 Height: 76
Compatible RØDE Accessories:	<ul style="list-style-type: none"> • RØDECaster DUO • Power Adapter • SC27 USB-C to USB-C Cable
Included Software:	RØDE Central

WHAT'S IN THE BOX



RØDECaster DUO



Power adaptor



SC27 USB-C cable

DIMENSIONS

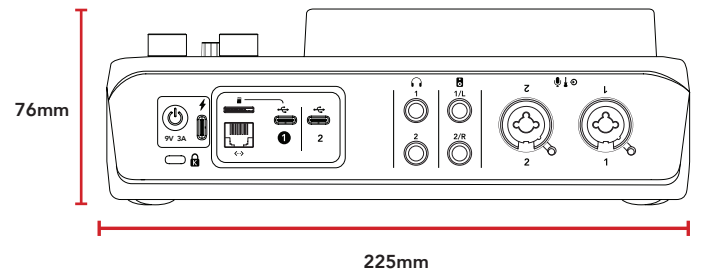
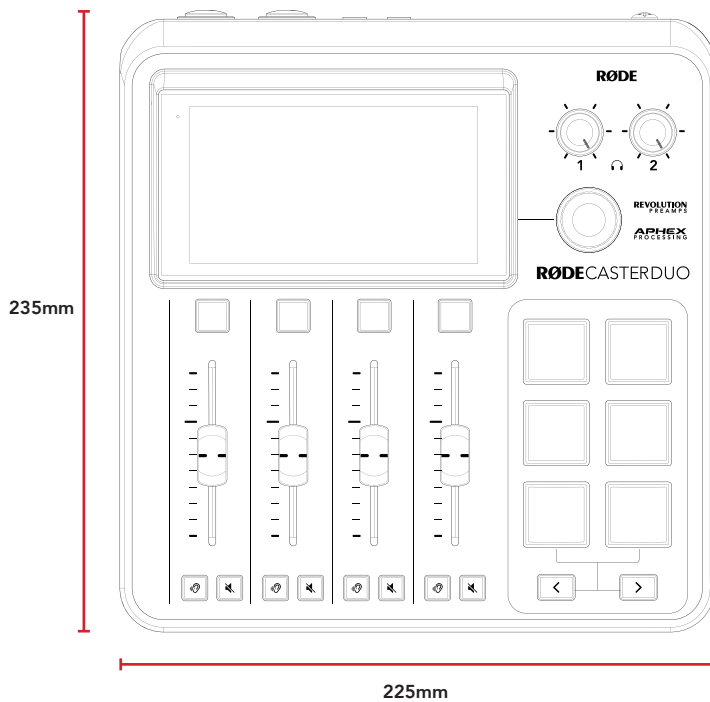

PODMIC

DYNAMIC PODCASTING MICROPHONE

The PodMic is a broadcast-quality dynamic microphone optimised for incredible performance in podcasting, livestreaming, and other speech or vocal applications. Offering a rich, full-bodied sound, with an internal pop filter for minimising plosives, internal shockmount for reducing vibrations, and a swing mount for easy positioning, the PodMic will take your content to the next level.

- Broadcast quality dynamic capsule
- Optimised for speech applications
- Internal pop filter to minimise plosives
- Robust, all metal construction
- Optimised for use with RØDECaster Pro consoles



BROADCAST
QUALITY



INTERNAL
POP FILTER



RUGGED BUILD



2
YEAR
WARRANTY



SPECIFICATIONS

Acoustic Principle:	Dynamic
Polar Pattern:	Cardioid
Frequency Range:	50Hz - 15kHz
Output Impedance:	320Ω
Sensitivity:	-57dBV (1.4mV @ 94dB SPL) +/- 2dB @1kHz
Output Connection:	XLR
Phantom Power:	Not required
Colour:	Black and White
Weight (grams):	937
Product Dimensions (millimetres):	Length: 172 Width: 109 Height: 62
Compatible RØDE Accessories:	PSA1+ DS1 DS2
Features list:	Integrated swing arm



Black



White

RØDE

WHATS IN THE BOX



PodMic
(Black or White)

DIMENSIONS

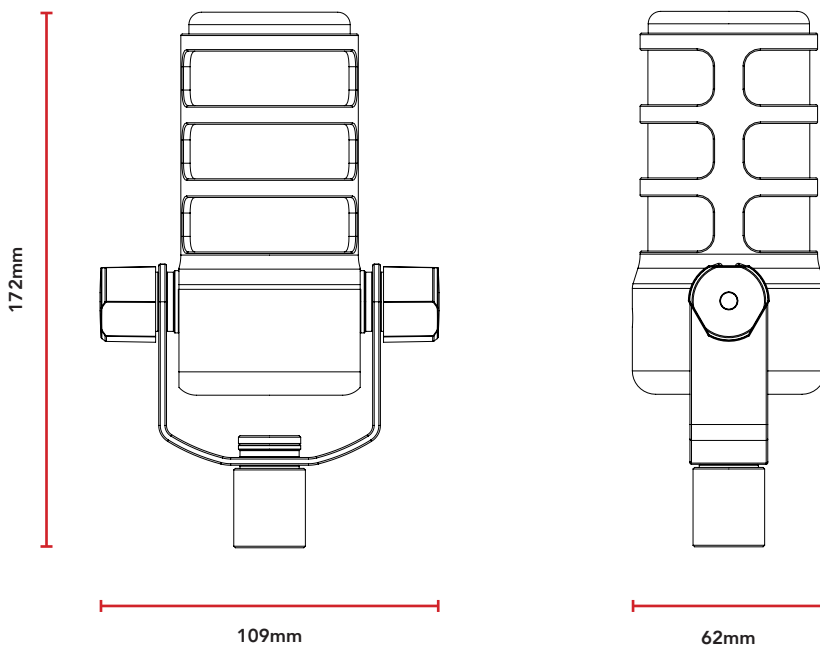

POLAR PATTERN

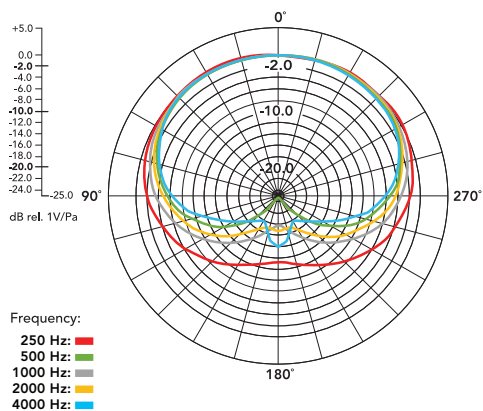

FREQUENCY RESPONSE

